

BTU, Mass & Energy Flow Sub-Metering Solutions

Accurate and Repeatable Sub-metering of Liquids, Gas & Steam



**DP
Flow Meters**



**Magnetic Flow
Meters**



**Vortex Shedding
Flow Meters**



**Coriolis
Mass Flow Meters**

BTU , Mass & Energy FLOW Sub-Metering Solutions



Magnetic Flow Meters

“Every flow technology has it’s place; nothing does everything”

To select the best solution for your application you should consider & compare:

- Accuracy vs Turndown
- Straight Run Requirements
- Permanent Pressure Loss (PPL)
- Installation Cost
- Cost of Ownership
- Ease of Maintenance
- Calibration and Meter Verification



Vortex Shedding Flow Meters



DP Flow Meters



Coriolis Mass Flow Meters





Magnetic Flow Meter Technology



Accurate and Repeatable Sub-metering of:

- Liquids – Chilled or Hot water
- Liquids - Condensate & Fresh water



Theory of Operation: Faraday's Law

Volumetric Flow: $Q = V * A$

Where:

Q = Flow rate

V = Velocity

A = Area

Faraday's Law: $E = kBDV$

or $V = E/kBD$

Where:

V = Velocity of conductor

k = Proportionality constant

E = Induced voltage

B = Magnetic field strength

D = Length of conductor

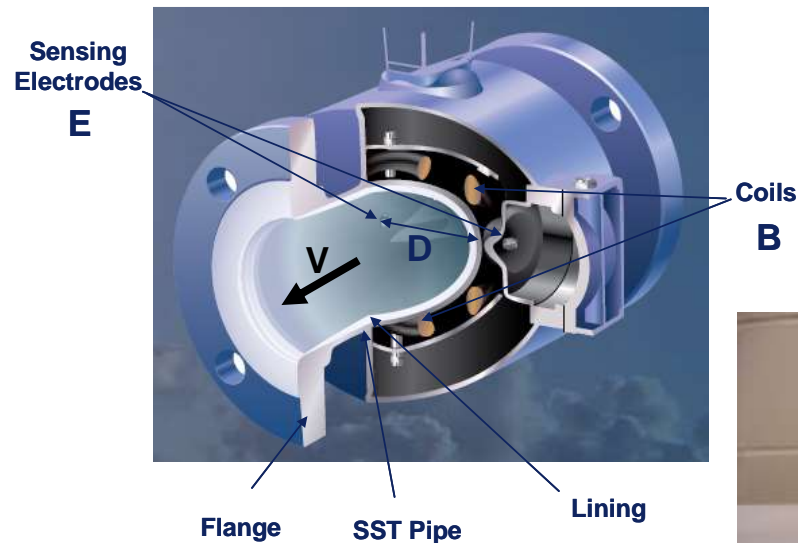

Flow of the conductive fluid induces a voltage that is directly proportional to the velocity of the fluid.

Magnetic Flow Meter Technology – Advantages

- **Reduce pumping (and energy) costs** - no additional pressure drop
- **Reduce maintenance costs**
 - no moving parts & non-clogging design
- **Increase accuracy** across flow range
 - From +/- 0.15% to +/- 0.5% of rate (1 - 30 ft/s rangeability)
 - Measure virtually to zero flow (low flow cut at (0.02 ft/sec) w/ reduced accuracy
- No re-zeroing and no calibration required; no mounting position affects
- Can measure **Bi-directional flow**
- Flow profile of process fluid has minimal effect on measurement accuracy
- Requires little to no straight runs
- Can be used for BTU calculations



Magnetic Flow Meters – Advancements: Meter Verification

- Magnetic flowmeters have **no moving parts**, and the expectation is that the meter calibration will never change
- Today's pulsed DC Magnetic Flow meters need no re-zeroing after installation because there are no mounting position effects
- Meter **verification** measures the flow tube sensors magnetic field strength characteristic to a very high accuracy. If the inductance and resistance are the same as it shipped from the factory, the health should still be good.
- If a **change** in the sensor magnetics is detected, **meter verification** determines whether performance remains within factory specifications and whether it should be re-zeroed.

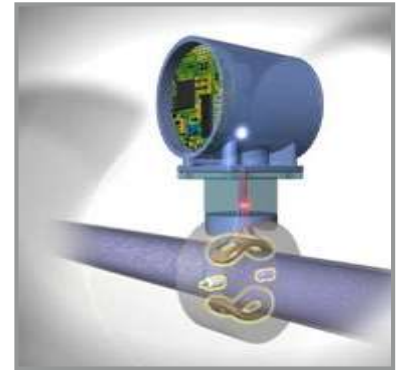

Meter Verification Delivers Pass/Fail for Calibration & Health

- A baseline signature of the magnetic field is taken at the time of factory calibration
 - Signature is independent of temperature and flow-rate
 - Signature (and calibration) will change if there is a mechanical shift of the coils over time due to vibration, thermal cycling, etc
- When Meter Verification is run, it compares the current magnetic signature value to the baseline signature stored in the transmitters non-volatile memory

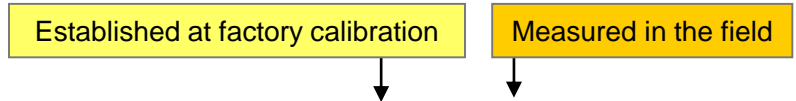

Sensor Parameter	Signature Baseline Values	8714i Measure Values	Deviation	Criteria	Pass/Fail
Coil Signature	19.5	19.6			
Coil Resistance	15.2	15.6			
Electrode Resistance	260.7	245.6			
Sensor Parameter	Signature Baseline Values	8714i Measure Values	Deviation	Criteria	Pass/Fail
Coil Signature	19.5	19.6	0.51%	1%	Pass
Coil Resistance	15.2	15.6		Range	Pass
Electrode Resistance	260.7	245.6		Range	Pass

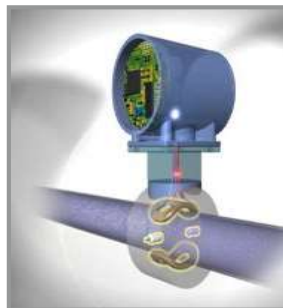

Rosemount's Magmeter Process Insight Diagnostics

High Process Noise

- Identify process noise and maximize signal stability with selectable coil drive frequencies

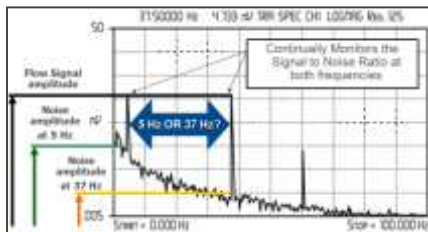

Digital Signal Processing

- If very high levels of 1/f or white noise are present, DSP or HIGH SIGNAL DC may be required

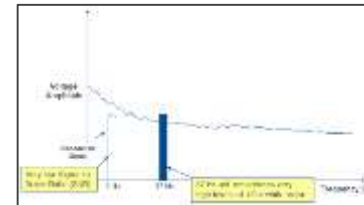

Grounding/ Wiring Fault

- Identify and address grounding/ wiring issues Prior to start-Up

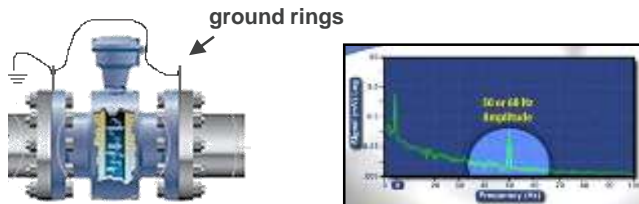

Electrode Coating Detection

- Identify coating before it becomes an issue



Magnetic Flow Meters - #1 Technology on BTU metering

- Chilled Water or Hot Water Supply
- High Performance Smart Temperature transmitters with calibrated sensors and “sensor matching” (calibrated RTD’s)
- One flow measurement plus inlet & outlet temperatures
- BTU & Delta T Calculations in BMS/BAS, PLC, FC



Energy Management Solution

Application
Chilled and
condenser water flow

ENERGY MANAGEMENT ROSEMOUNT E-SERIES

Performing Arts Center Decreases Energy Consumption and Billing System Errors with E-Series Magnetic

RESULTS

- Increased billing accuracy
- Increased flow accuracy
- Reduced maintenance costs

APPLICATION
The Rosemount E-Series magnetic flow meter helped the customer optimize chilled water flow and reduce metering errors.

CHALLENGE
The Rosemount E-Series magnetic flow meter helped the customer optimize chilled water flow and reduce metering errors.

SOLUTION
The Rosemount E-Series magnetic flow meter helped the customer optimize chilled water flow and reduce metering errors.

RESULTS
The Rosemount E-Series magnetic flow meter helped the customer optimize chilled water flow and reduce metering errors.

ROSEMOUNT Emerson

• CHALLENGE

- Problems controlling flow rate of primary & secondary chilled water loops within cooling system.
- Previous flow meters.
 - Didn't cover full measurement range
 - Inaccuracies & poor responsiveness
 - No verifiable way to device was reading appropriately
- Negative Business Impacts
 - inaccurate billing, poor consumer confidence, additional operations & maintenance costs

• SOLUTION

- Rosemount E-Series Magnetic Flow Meter
 - High Accuracy D1 Option & Meter Verification

• RESULTS

- Increased Billing Accuracy & Confidence
- Reduced Maintenance Costs



Vortex Shedding Flow Technology

Accurate and Repeatable Sub-metering of
Liquids, Gas & Steam





Principles of Vortex Shedding

- Based on the von Karman Effect
 - Fluid alternately separates from each side of the shedder bar face
 - Vortices form behind the face and cause alternating differential pressures (DP) around the back of the shedder bar
 - The frequency of the alternating vortex development is linearly proportional to flow rate

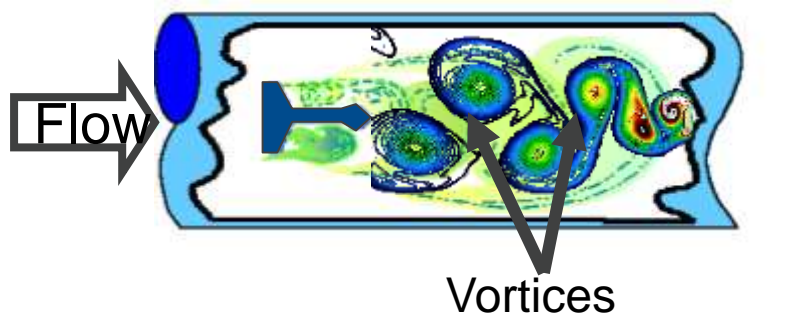

Vortex Shedding Flow Meter Applications

- Relatively Clean Liquid, Gases and Steam
 - Some designs can push this limitation depending on design!
- Wide Temperature Range Applicability
 - From -328 F to 800 F (-200C to 427C)
- Wide Range of Line Sizes
 - 1/2" through 12"+ (15mm through 300mm)
- Some Designs: Ports or crevices to clog



Vortex Shedding Flow Meter Advantages

- Wide Rangeability
 - up to 35:1 Meter Rangeability or Turndown
- High Accuracy
(0.65% of flowrate on liquids; 1.00% Vol. on gas & steam, 1.5 to 2% mass flow rate when compensated)
- High Reliability; No moving parts
- Minimal Fugitive Emission Points
- Loop Powered; 2 wire device
- Low Pressure Drop
- In-Line Flow-Through Installation
 - No Impulse Piping, no wet legs, no heat trace required outdoors
- Frequency-based Measurement
 - No periodic maintenance for zero or span shifts



Advantages of Single Casting Meter Body Design with External Sensor

- No Process Ports or Crevices to Plug
- Sensor Can be Replaced without Exposure to Process
 - No calibration shifts
- No O-ring Material Compatibility Issues
- Fewer Sources of Fugitive Emissions

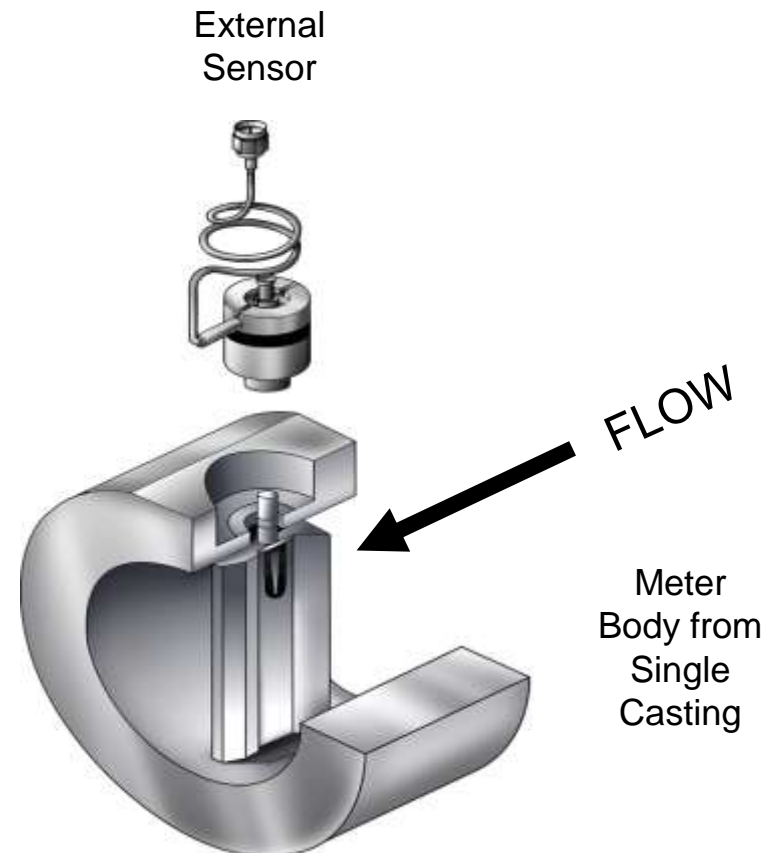

Steam - Customer Challenge at We Energies



Application

Saturated Steam, 150 psi,
District Energy - Billing meters
for over
500 + customers



- CHALLENGE

- Measure accurately for billing & custody transfer
 - 100's of customers
 - Inaccurate billing
 - Customer confidence
- Avoid costly annual calibrations
 - Additional maintenance & cost
- Some technologies like dP include wet-legs which require heat trace and insulation on outdoor installations
 - Additional cost and maintenance

Steam ...and the Solution was.....



Application

Saturated Steam,
150 psi, District
Energy - Billing
meters for 100's of
customers



Proven Results:
00830-1300-4004, Rev AA

Solution in this case was Multi-Variable Mass Vortex for Saturated Steam

- Temperature compensated for accurate mass flow
 - Accurate Mass Billing
 - Improved Customer Confidence
- No installation affects, no zeroing or re-zeroing
 - Reduced Start-up cost & maintenance cost
- Built in Frequency generators
 - For Meter Verification & Health
 - Reduced calibration and maintenance cost
- No impulse lines or wet legs
 - No heat trace required
 - Reduced cost



DP Flow Meter Technology

Accurate and Repeatable Sub-metering of
Liquids, Gas & Steam



Flow Technology – DP Flow

- Primary elements used to create a pressure drop



- Bernoulli's Theorem – an energy balance around 2 different points in a flow stream, DP Flow is Differential Pressure generated by a primary element in the line which is proportional to flow

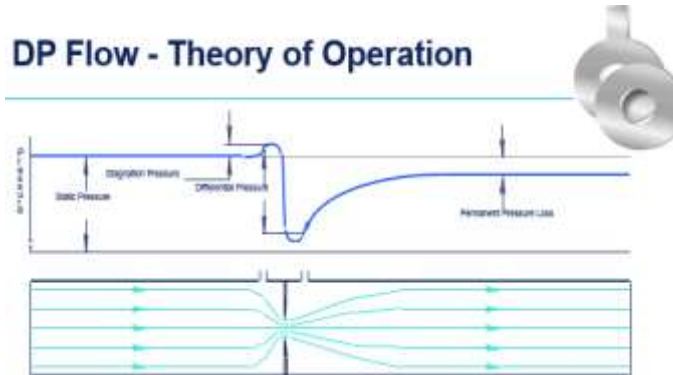
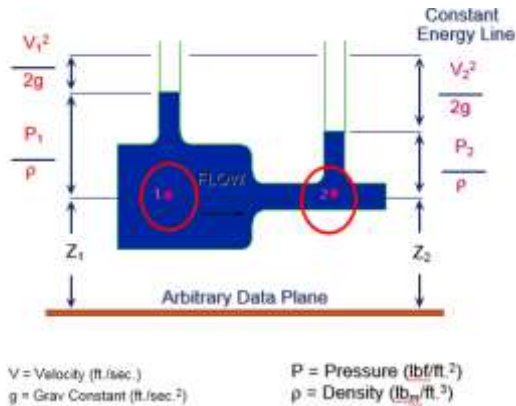

$$Q_{mass} = NC_D Y_1 E d^2 \sqrt{DP(\rho)}$$

- Common Uses – Steam, Water, Condensate, Air, Natural Gas and most utility applications



Advantages & Advancements of DP Flow

- NUMEROUS Primary Elements – to handle all line sizes, fluids and temperature and pressure
- FLEXIBLE & Smart Sizing for useable turndowns
- CUSTODY TRANSFER
Accuracy up to +/- 0.75% of mass flow rate
- REDUCED STRAIGHT RUNS - Conditioning Plate technology – requiring only 2 Diameters upstream & 2 Diameters downstream in most installations
- ULTRA for FLOW – “designed & characterized in” for larger turndowns & accuracy at lower flow rates
(ie. +/- 1% mass flow over 14:1 turndown)

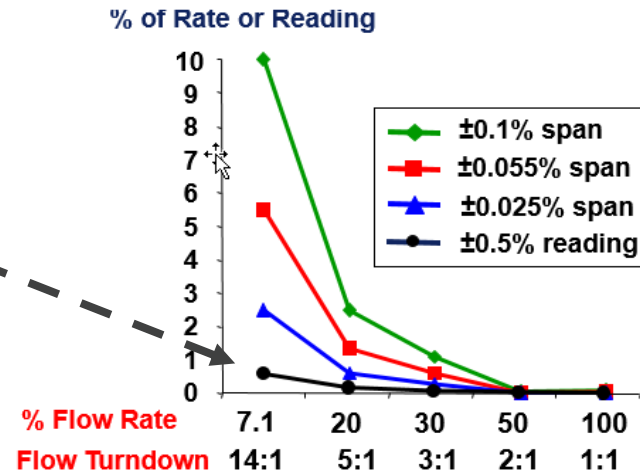
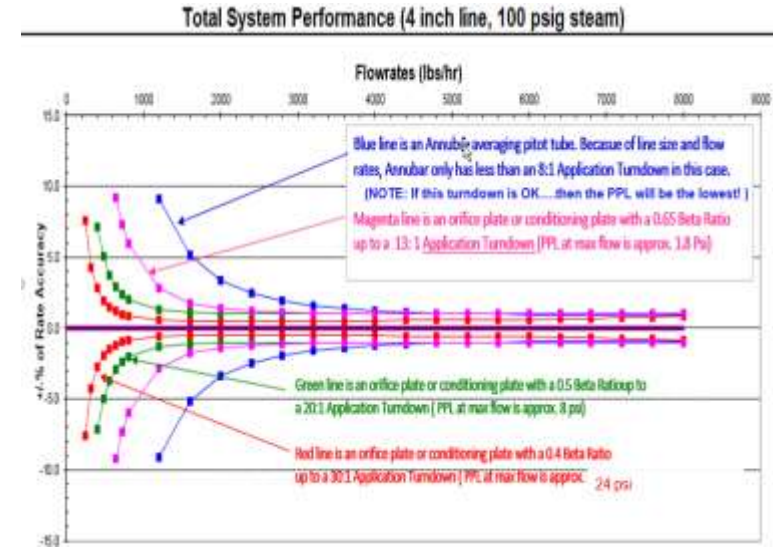

Sub-metering of STEAM with compensation built-in



- Steam is a compressible fluid – typically requires P or T compensation on Saturated Steam, and both P & T compensation on Super Heated Steam
- Up to 3 process measurements in one device – DP, P & T
Includes a built-in flow computer & totalizer – Reduces Installed Cost
- Can calibrate all 3 internal transmitters to NIST traceable standards
....in the pipe – Maintains Accuracy and builds Customer Confidence
- Accurate Custody Transfer – Builds Customer Confidence
- 15 Year stability Specification – Long Term Accuracy & Reliability
- Assembled, Leak Tested, Configured and Calibrated – Installation Ready
Reducing Installed Cost and Risk, Accurate & Repeatable



Multi-Variable DP FLOW

Improves Accuracy & Reduces Cost

- CHALLENGE: Large seasonal flow turndown
- SOLUTION:
 - Smart sizing for useable turndown – balance DP with Perm. Pressure Loss (PPL) for accuracy over turndown
 - Ultra for Flow for accuracy at lower flows for larger turndowns – eliminates stacking of transmitters in most applications or having to switch out orifice plates for seasonal load changes
- CHALLENGE: Limited straight runs for Installation
- SOLUTION:
 - Conditioning plate primary elements require only 2D's upstream and 2 D's downstream in most installations
- CHALLENGE: Minimizing Installed cost
- SOLUTION:
 - 3 transmitters and a flow computer built in one device Reducing Installation & Commissioning Cost

University Successfully Reduces Utility Costs with Conditioning Orifice and MultiVariable™ Technology

RESULTS

- Improved steam management
- Reduced energy/utility costs
- Reduced operations and maintenance costs

APPLICATION

Steam flow metering at 12 university buildings

CUSTOMER

University in Northeast USA

CHALLENGE

A university in northeast USA experiences a high steam output during the winter months while heating 12 of the campus buildings, and low output during the summer months when heating is not necessary. Because of the varying flow rates throughout the year, the university was not monitoring their steam flow usage due to the problems associated with traditional technology.

Traditional differential pressure transmitter technology did not allow for accurate readings during the low flow periods of the summer months. Instead, orifice plates would need to be switched with smaller beta orifice plates during these low flowing periods in order to increase the DP measurement signal so that the transmitter can accurately read the flow. Another option the Project Engineer faced was "stacking" transmitters at each measurement point, using the high range transmitter during the high flow months and the low range transmitter for the low flow months. This, however, would lead to the added cost of purchasing and installing two transmitters for every measurement point. Finally, there was limited straight pipe run available that did not allow for conventional orifice plates to be installed without the increased cost of flow straighteners.



The high turndown capability of the 3051SMV eliminated the need to seasonally swap orifice plates or stack transmitters.



Figure 1. 3051S MultiVariable Transmitter



Multi-Variable DP FLOW Compensation Improves Accuracy



• CHALLENGE:

- Primary elements can have flow coefficients that are not linear over their flow range

• SOLUTION:

- Multi-variable flow transmitters that have compensation variations in Flow Coefficients “built-in”
- 3 transmitters and a flow computer built-in for dynamic compensation (DP, P & T)
- Reduces cost of accurate custody transfer of steam
- Output is mass flow

VALUE PROOF

Want to eliminate \$288,000 a year in lost steam by eliminating bias error?

Solution

In the steam generation industry, piping leaks and condensation mean that some loss of billed steam is inevitable. Control what can be controlled! Eliminate bias error in flow measurement with Rosemount's Model 3095 MV™ Multi-variable™ Mass Flow Transmitter.

- **Eliminate measurement errors** caused by gas expansion.
- **Addresses six flow rate measurement factors.** The Model 3095 MV accounts for changes in the discharge coefficient, velocity, bore diameter, and density in addition to change from gas expansion.
- **Eliminate bias error.** Real time flow calculations performed by the Model 3095 MV ensure the greatest DP flow accuracy across the widest operating range of any mass flow transmitter on the market.



Flow Rate Uncertainty Comparison

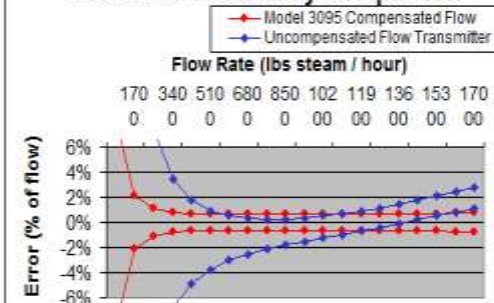

Proof

A steam generation facility provides steam for 80 large office buildings, each with its own transmitter installation.

- **1% of the lost steam is recovered** for each installation each month. Steam recovery was more than 1% during low output months.
- **\$300 savings per installation per month.** Total steam dollar flow rate per installation is approximately \$30,000. One percent recovery translates into \$300/month.

- **Billing efficiency increases \$288,000 annually.** The utility in this example saves \$300 monthly at 80 installations. $(\$300 \times 80) \times 12 = \$288,000$ Bias error reduction from advanced flow compensation is only one reason to install the Model 3095 MV. Accurate measurement of multiple variables, flexible and less intrusive connection configurations, and compact packaging make the Model 3095 MV an easy choice for mass flow measurement installations!

DP Flow Measurement Point Summary for Steam and Boiler Systems

1. Compact Conditioning Flow Meter
2. Annubar™ Flow Meter
3. Compact Annubar™ Flow Meter
4. Main Steam Annubar™ Flow Meter

