



# HEAT PUMPS FOR DISTRICT HEATING **AND** COOLING -A CASE FROM COPENHAGEN

Jens O. Hansen  
Business Development Director, Energy Systems



# WHY HEAT PUMPS?

**Electrification**

**Use of alternative  
sources**

**Costs**

# BUNHILL, LONDON, UK

## WASTE HEAT FROM THE METRO AND A POWER TRANSFORMER

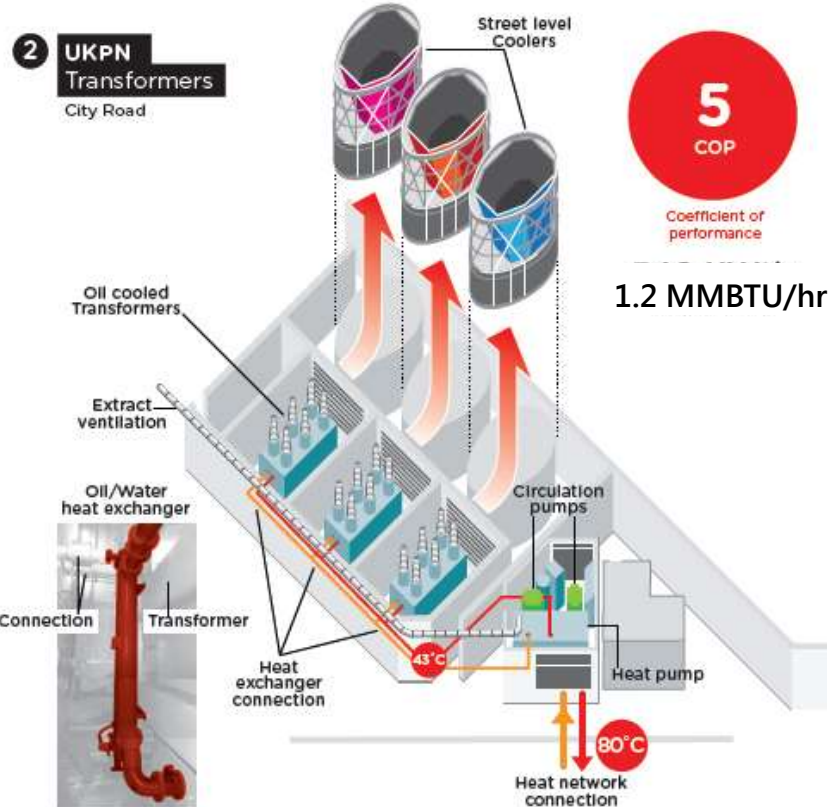
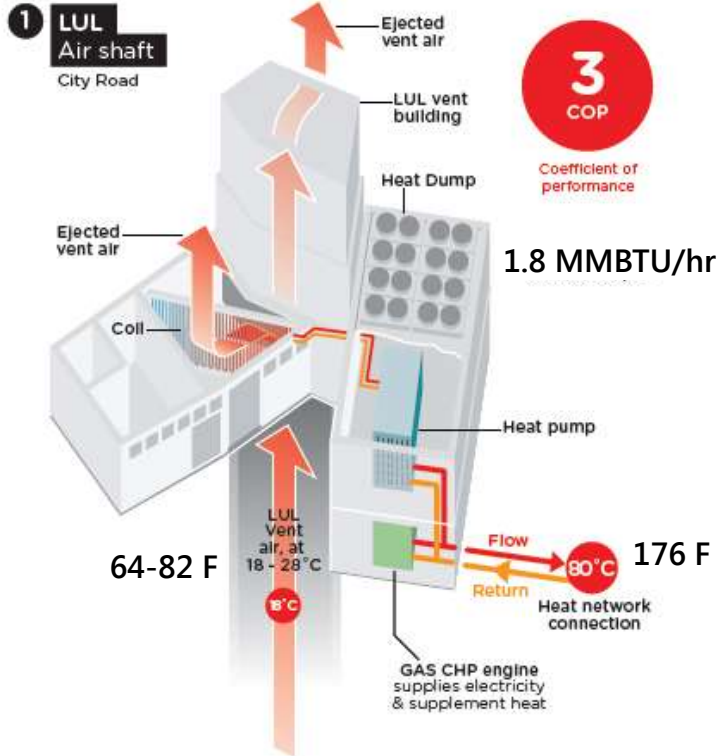

# QUEENS QUAY, SCOTLAND

## RIVER

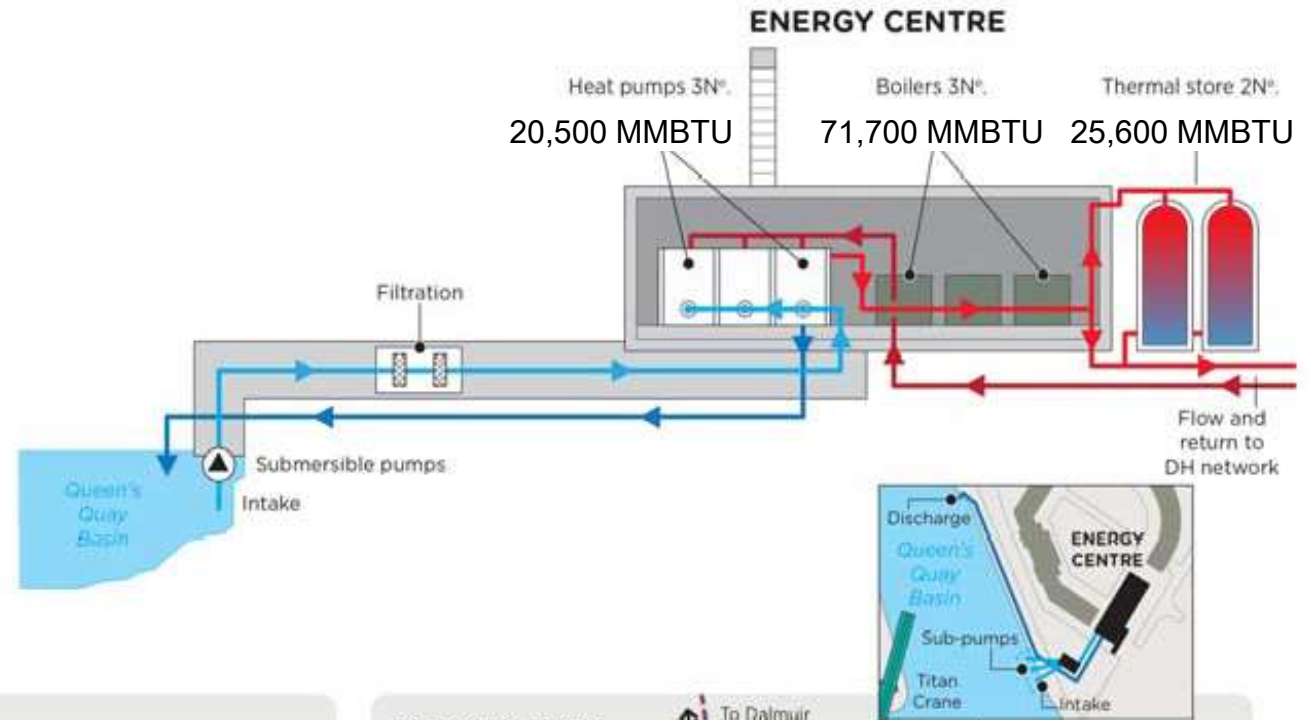
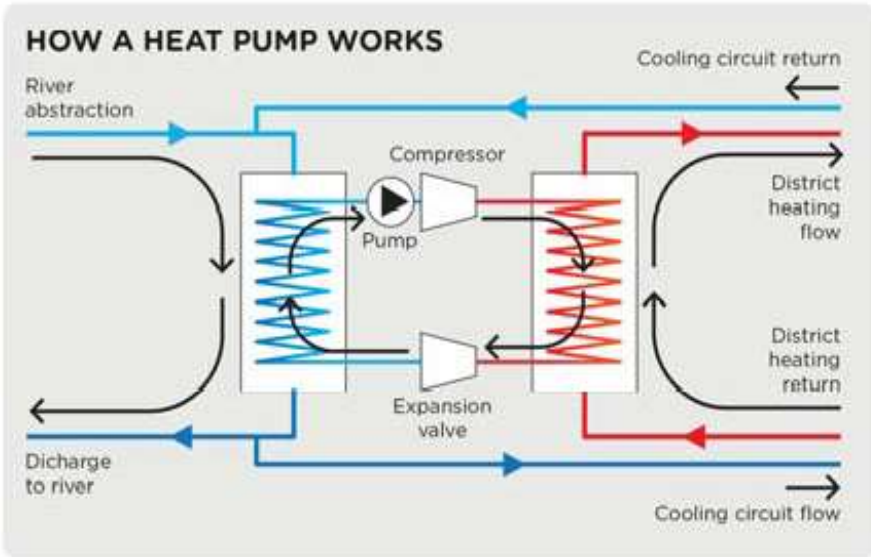
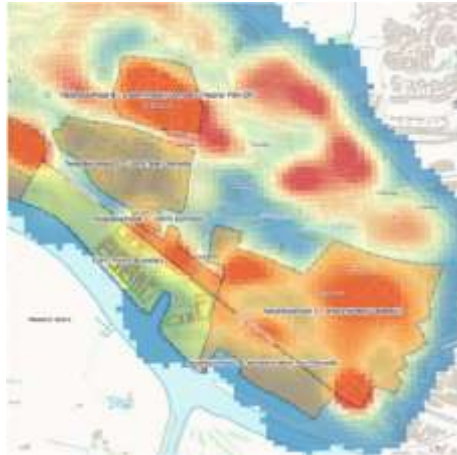
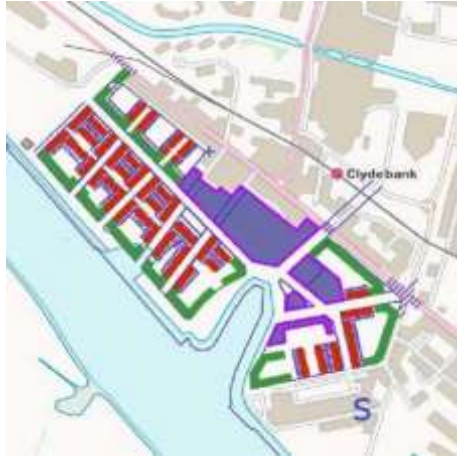

# HEAT PUMP PLANT NEXT TO HYPER-SCALE DATA CENTER, ODENSE, DENMARK



Visualization: Archidea Architects

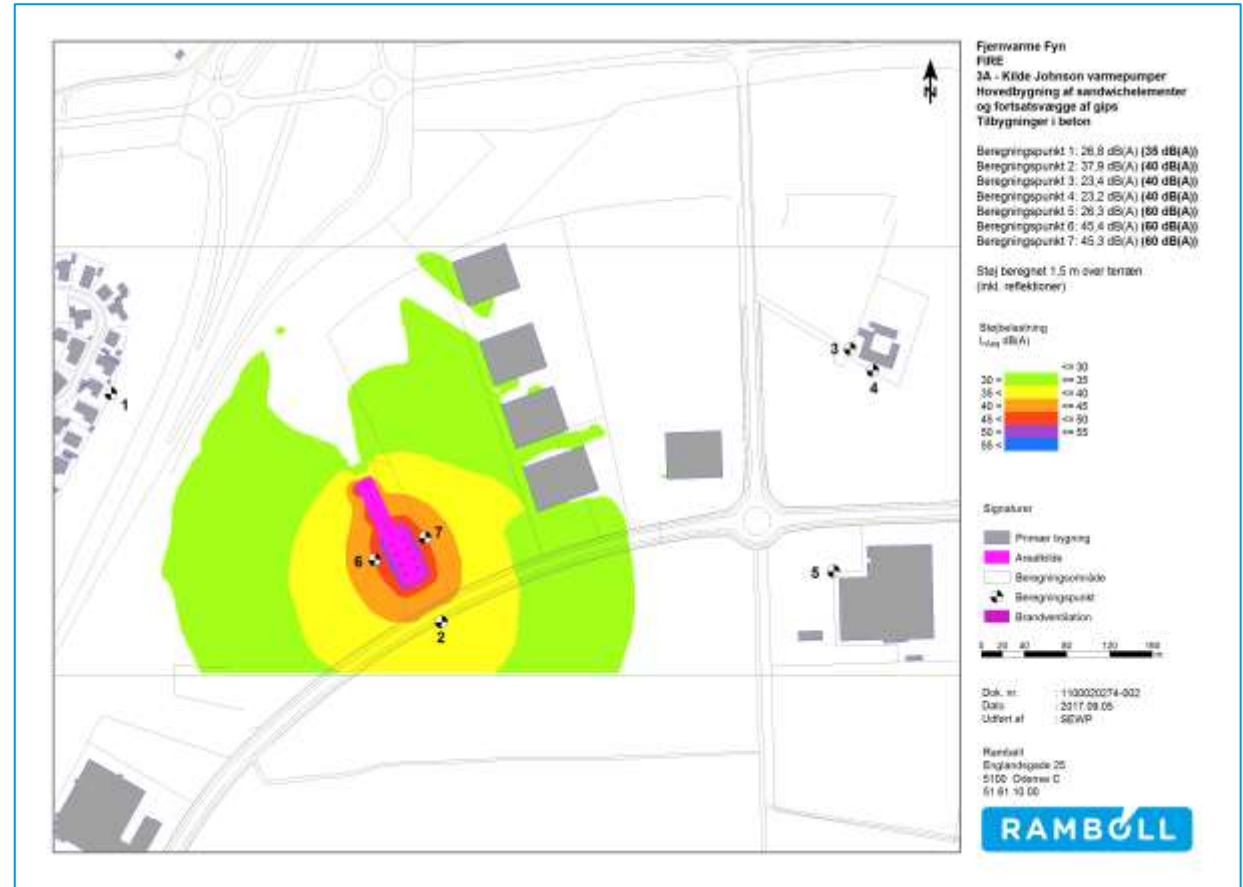

Noise limitations: 45/40/40/35 dB (day, evening, night)



CASE:  
HP for heating  
and cooling

# HEAT PUMP FOR DISTRICT HEATING AND COOLING TAARNBY, COPENHAGEN, DENMARK

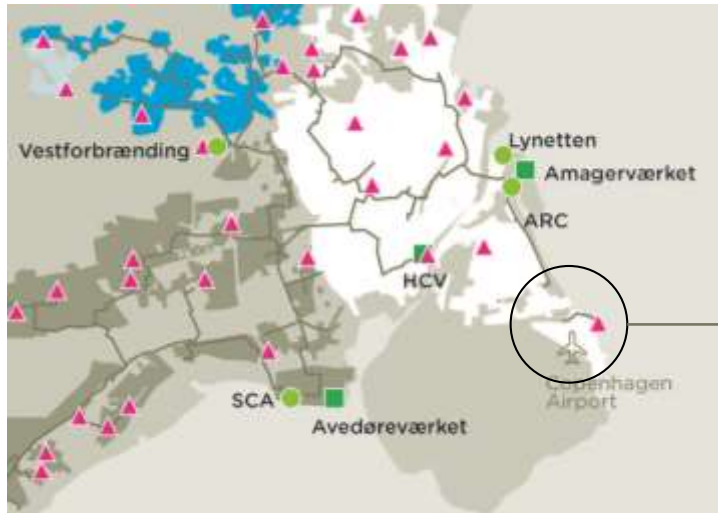

Visualization: Ramboll



# BY THE NUMBERS

Number	
Number of buildings	11
Floor area, sq.ft	1,830,000 sq.ft

Cooling production	
Heat pump cooling	1,300 ton
Storage Tank (2,000 m3)	700 ton
Ground Source Cooling, ATES	600 ton
<b>TOTAL COOLING CAPACITY</b>	<b>2,600 ton</b>

Heating production	
TOTAL heat pump heat	6.7 MW
-combined heating and cooling	22%
-heat from waste heat	78%

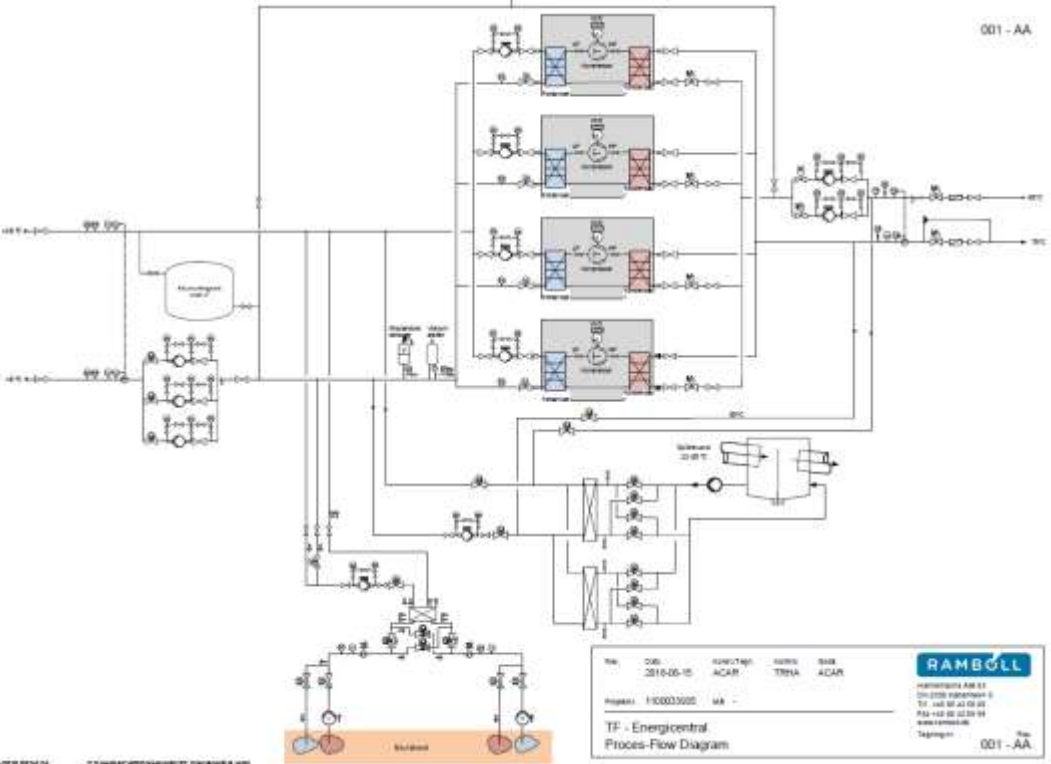



# ECONOMICS

Number	
Number of buildings	11
Floor area, sq.ft	1,830,000

CAPEX	MUSD
Plant Building	0.6
Ground source cooling	1.4
Heat Pump	6.3
Waste water heat exchanger	0.3
Chilled water tank	0.6
District cooling network	2.2
ETS	0.8
Connection of DH network	0.5
TOTAL	12.3

NET PRESENT VALUE	MUSD
Society, socio-economics	16
Utility	8
End-users	1.2

# QUESTIONS & ANSWERS

**Jens O. Hansen**

Business Development Director,  
Energy

M +45 51618591  
jeoh@ramboll.com

---